



International Bridge Technology Exhibition
Rotterdam, the Netherlands
November 15-16, 2005

EXHIBITORS MANUAL

A.	THE EXHIBITION	2
B.	INTERNATIONAL BRIDGE ENGINEERING CONFERENCE	2
C.	TECHNICAL SITE VISITS	2
D.	TARGETED EXHIBITORS	2
E.	TARGETED VISITORS	3
F.	STAND INFORMATION	3
G.	EXHIBITION PLAN	4
H.	RULES & REGULATIONS	4
I.	STAND ALLOCATION	5
J.	COSTS	5
K.	PAYMENT	5
L.	CANCELLATIONS	6
M.	EXHIBITOR BADGES	6
N.	ACCOMMODATION	6
O.	PROMOTIONAL PLAN	6
P.	SPONSORING OPPORTUNITIES	7
Q.	IMPORTANT CONTACT DETAILS	7

A. THE EXHIBITION

Brisk Events presents BridgEneering. The BridgEneering exhibition will cover an exhibition area of 1.000 m², expecting over 30 exhibitors. Brisk Events, the exhibition organisers offer exhibitors the opportunity to present their products and/or services at BridgEneering at the Maas Building in Rotterdam, the Netherlands. This exhibition is dedicated to the architectural and engineering bridge building society.

An International Bridge Engineering Conference and 3 Technical Site Visits will coincide with the exhibition. Exhibitors and visitors are invited to attend the conference and one of the Site Visits at an additional charge.

B. INTERNATIONAL BRIDGE ENGINEERING CONFERENCE

The International Conference will have presentations on Bridge Engineering, Bridge Technology and the most innovative bridge projects in the world. COBRAE, the COMposite BRidge Alliance Europe, will arrange a session on the subject of "Light Weight Bridge Technology".

The Conference Programme will be made available on the BridgEneering website. To submit a paper, contact Mr. Jaap Ketel at +31 33 4343 500 or by email: info@briskevents.nl. A Technical Conference Committee will be judging the submitted papers. The time schedule will be published on the BridgEneering website.

C. TECHNICAL SITE VISITS

The day prior to the BridgEneering Exhibition, Monday 14 November 2005, three excursions are planned to newly build bridges in the Netherlands. A choice can be made of the following different site visit tours:

- Calatrava bridges in Holland
- HSL-South bridges in the High Speed Railway Line
- Rotterdam local bridges by boat, architectural tour

Details of the visits will be made available at a later date in a separate conference announcement and on the BridgEneering website.

D. TARGETED EXHIBITORS

BridgEneering has extended invitations to exhibit to all sectors of the Bridge Engineering industry, covering:

- * Consulting & Engineering Firms
- * Architects & Design Engineers
- * Bridge Fabricators & Contractors
- * Pre- & Post-Stressing Companies
- * Lightweight Structural Materials Producers
- * Bridge-Deck Manufacturers
- * Cables, Suspension Systems, Dampers etc.
- * Monitoring Systems
- * Security Systems
- * Truck Weighing & Oversize Load Warning Systems
- * Toll & Access Control Systems
- * All other related products and services

E. TARGETED VISITORS

BridgEneering will be open to registered visitors at € 25,-. Exhibitors will receive a limited number of free entrance cards to be sent to their contacts and to be used by stand attendees. Cards are valid on both days and are not personalised.

Amount of entrance cards per stand:

6 m ² stand	30 entrance cards
9 m ² stand	45 entrance cards
12 m ² stand	60 entrance cards

Extra tickets are available to the exhibitor at € 5,- per ticket. These tickets will give free access to the exhibition only and not to the conference or the excursions.

Invitations to attend the Exhibition as visitors will be extended to Architects, Consultants, Design Engineers, Component Suppliers, Manufacturers, Fabricators and Researchers and all other related activities. The exhibition will provide a professional forum in which exhibitors can meet potential customers and develop future partnerships. Invited visitors pay a reduced fee to access the exhibition.

Over 400 professional visitors are expected to attend the exhibition over the two days.

F. STAND INFORMATION

There are around 30 pre-built shell scheme stands available for exhibition purposes (please refer to enclosed exhibition plan). Stands are uniform but are varying in width and depth. Shell scheme is rented per m². On special request exhibition space without shell scheme can also be rented per m².

Stands are built with Octanorm system. Walls are module panels, one meter wide and covered in plastic material. The panels are white in colour. Other colours are available upon request at an additional charge.

Each stand with a minimum of 2 m x 3 m and 2.5 m height. Furniture and other exhibition requirements such as counters, stands and displays are not included. If you wish to order furniture, please visit our stand builders website. Here you will find a full list of available furniture and an order form. Orders are to be placed directly with the stand builder, 'Holland Reklame en Standbouw'.

http://www.hrsb.nl/indexhvb_uk.html

Your company name will be mounted on the fascia of the stand with 50 mm high Helvetica lettering, of max. 20 letters.

On the walls 2 x 100 Watt spots are mounted for lighting. Bigger stands will have extra lights.

For electricity supply, there will be a 5 amp (240 Volts) earthed DIN type socket in each stand.

Floor covering is not included. Floor is smooth vinyl. Luxury floor can be rented from the stand builder.

Exhibit build-up:	Monday 14 November 2005	15.00 - 20.00 hrs
	Tuesday 15 November 2005	08.00 - 11.00 hrs

Stand construction and furnishing is not permitted after 11.00 hrs on Tuesday 15 November 2005.

Removal of exhibit: Wednesday 16 November 2005 15.00 - 22.00 hrs

Exhibition opening times are:

Tuesday 15 November 2005 12.00 - 19.00 hrs

Wednesday 16 November 2005 10.00 - 15.00 hrs

Brisk Events takes no responsibility for the presentation of the exhibited material.

G. EXHIBITION PLAN

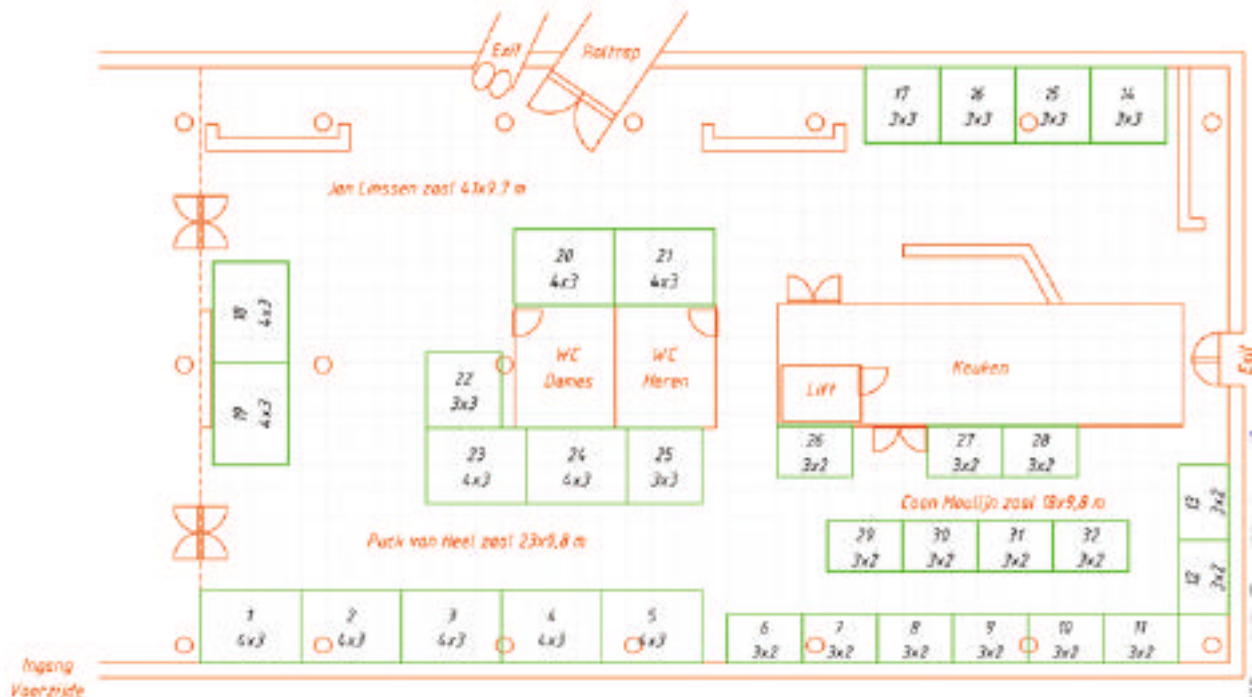

Stands with a full column inside qualify for a 20% reduction in m² fee.

N.B. For large size exhibits not fitting in the stands, an opportunity exists on the parking area in front of the Maas Building. Please contact the organisers for details.

H. RULES & REGULATIONS

To avoid damages to the wall panels, companies have to comply to the following rules:

- It is not allowed to drill, screw, to nail or to staple the wall panels.
- It is not allowed to write on the wall panels with ballpoint pens, pencils, felt tip or similar.
- Please do not use any type of fixing material that causes glue to remain or cause damage to the wall panels and aluminium sections. If 'Holland Reklame en Standbouw' (the exhibition stand building company) has to remove any remainders you will be charged for the cleaning costs.
- We are obliged to charge you an amount of € 35,- per damaged wall panel.

Note: for the hanging up of materials you can obtain for a small fee brackets or yellow carpet-tape at the organisation. Alternatively you can also use nylon fibre which can be fixed on the upper side of the wall panels.

All materials shall be exhibited at the exhibitors own risk. It is advised that exhibitors insure their products & equipment against damage and loss. It is the responsibility of all exhibitors to insure themselves against personal injury.

The Maasgebouw and Brisk Events will not be responsible for any damages or loss.

I. STAND ALLOCATION

Stands are allocated by Brisk Events. Exhibitor's preference will be honoured as much as possible, giving priority to those booking early. Reservations for stands become final and confirmed only after payment of 50% of the total exhibition fees.

J. COSTS

Costs (excluding 19% VAT/BTW) for participating in the exhibition are:

Registration cost:	€ 350,-
Costs stand:	€ 160,- per m ²
Stand prices:	2 x 3 m = 6 x 160,- = Euro 960,-
	3 x 3 m = 9 x 160,- = Euro 1.440,-
	3 x 4 m = 12 x 160,- = Euro 1.920,-

A 20% reduction in m² fee applies to stands with a full column inside.

Included services are: Uniform shell scheme, stand lighting, company name on facia, cleaning of stand, free listing in exhibition catalogue and website, link to company website, limited number of free invite tickets for qualified business contacts.

There is an additional charge for attending the conference and technical site visits.

K. PAYMENT

To register for BridgEneering please return the registration form to Brisk Events.

Stand registration will be invoiced and must be followed within 30 days by a payment of 50% of the total stand rental. The remainder is to be paid no later than October 1st, 2005. Registration and payment for the conference and technical site visits will be effected separately.

VAT/BTW charges are refundable for non Netherlands companies on special request. Brisk Events can provide the exhibitor with the necessary documentation.

Brisk Events is a subsidiary of Ketel Consulting Agents BV. Only after receipt of invoice, payment can be made by International Bank Transfer to:

Ketel Consulting Agents BV/ Brisk Events

ABN-AMRO Bank, Kooikersgracht 11, Leusden, NL

Account number: 59.55.41.216

IBAN number: NL41 ABNA 0595541216

BIC number: ABN ANL 2A

BTW (VAT) registration number: NL811896948B01
Please quote BridgEneering, Stand No, Invoice No and Debtor No.

L. CANCELLATIONS

In case of cancellation of the stand, a refund will be made on the square meter cost. The registration cost is not refundable.

More than three months before the exhibition:	Full refund
Between three months and 1 month before the exhibition:	50% refund
Less than 1 month before the exhibition:	No refund

Please note that no refunds can be made on any payment when the stand is not occupied.

M. EXHIBITOR BADGES

Exhibitors are responsible for providing their own company badges for exhibition personnel. Entrance cards for exhibition personnel are included in the limited number of free exhibition entrance cards.

Limited entrance cards (value € 25,-) will be made available to exhibitors as invitations to their contacts (refer to item E).

N. ACCOMMODATION

All exhibitors, delegates etc. are responsible for booking their own accommodation. For more information on accommodation visit the tourist site of Rotterdam:

<http://www.vvv.rotterdam.nl/uk/>

O. PROMOTIONAL PLAN

The BRISK EVENTS organization has many long term established contacts in the world-wide Bridge Engineering world. A data base of over 5.000 contacts in Europe is available for direct mail together with a similar size E-mail-database.

Input Exhibitors

Exhibitors can make their list of contacts available for direct mailing by Brisk Events. Invites will be mailed with exhibitor's name listed on these free access tickets.

Website

All exhibitors will be listed on the BridgEneering website with a link to the Brisk Events website.

Exhibition Catalogue

An exhibition catalogue will be published on the website and in print available during the exhibition.

Supporting organisations

BridgEneering is supported by COBRAE, the COmposite BRidge Alliance Europe, arranging a session on the subject of "Light Weight Bridge Technology" during the conference. The names of other supporting organisations will be published in the final exhibition announcement, on the free access tickets and on the BridgEneering website.

P. SPONSORING OPPORTUNITIES

Special sponsor opportunities will be available, such as gifts, brochure bags, etc. Please contact the organisers.

Q. IMPORTANT CONTACT DETAILS

- Organiser:** **Brisk Events**
Mr. Jaap H. Ketel
PO Box 18
3830 AA Leusden
The Netherlands
Tel: +31 33 4343 500
Fax: +31 33 4343 501
Email: info@briskevents.nl
<http://www.bridgEneering.com>
- Stand Builder:** **Holland Reklame en Standbouw**
Mr. Joop Peeters
Nijverheidsweg 30-36
3899 AJ Zeewolde
The Netherlands
Tel: +31 36 - 522 56 66
Fax: +31 36 - 522 56 60
E-mail: office@hrsb.nl
<http://www.hrsb.nl>
- Venue:** **Maasgebouw, Feyenoord NV**
Mrs. Zara Ghzilli
Postbus 9649
3007 AP Rotterdam
Tel: +31 10 - 492 9455
Fax: +31 10 419 1888
E-mail: sales@dekuip.nl
<http://www.dekuip.nl/>